



中山醫學大學附設醫院

直腸癌診療指引

本臨床指引參考台灣國家衛生研究院、與美國NCCN版本

大腸直腸癌多專科醫療團隊編修

2023/12/26 Version 17.0
2022/12/20 Version 16.0
2021/11/16 Version 15.0
2020/12/01 Version 14.0
2019/11/19 Version 13.0
2018/11/15 Version 12.0
2017/12/21 Version 11.0
2016/12/01 Version 10.0
2015/12/24 Version 9.0
2014/12/18 Version 8.0
2013/12/26 Version 7.0

癌症委員會主任委員	癌症委員會執行長	癌症中心主任	團隊負責人

修訂內容

頁數	原文	修訂/新增								
P8	<p>Rectal Cancer Work Up</p> <p>Major Dignosis</p> <ul style="list-style-type: none"> ● Colonoscopy ● Chest CT and abdominal CT or MRI ● Biopsy ● Pathology review ● Flexible Sigmoidoscopy + Double contrast Barium enema ● Pelvic MRI 	<p>Rectal Cancer Work Up</p> <p>Major Dignosis</p> <ul style="list-style-type: none"> ● Colonoscopy ● Chest CT and abdominal CT or MRI ● Biopsy ● MMR/MSI-H testing ● Pathology review ● Flexible Sigmoidoscopy + Double contrast Barium enema ● Pelvic MRI 								
P8	NA	增加 IVC 期別								
P11	NA	<p>TagerOX</p> <table border="1"> <tr> <td>UFUR</td> <td>250-300 mg/m2/day po bid</td> </tr> <tr> <td>14 days</td> <td></td> </tr> <tr> <td>Oxaliplatin</td> <td>130 mg/m2 iv</td> </tr> <tr> <td>d1</td> <td></td> </tr> </table>	UFUR	250-300 mg/m2/day po bid	14 days		Oxaliplatin	130 mg/m2 iv	d1	
UFUR	250-300 mg/m2/day po bid									
14 days										
Oxaliplatin	130 mg/m2 iv									
d1										

頁數	原文	修訂/新增
P10		
P14		

目 錄

一、前言.....	2
二、組織病理分類與分化.....	2
三、分期.....	3
四、直腸癌診療指引.....	6
五、化學治療處方.....	8
六、放射線治療.....	14
七、放射線治療原則.....	15
八、手術治療原則.....	17
九、實症醫學.....	24
十、安寧緩和照護原則.....	24
十一、參考文獻.....	25

一、前言

本直腸癌治療指引內所提之各種診治意見，為實證醫學原則之建議，希望能為癌症患者及其家屬提供一個正確的指引；但對臨床醫師之醫療行為無絕對之法律性約束力！由於醫藥科技持續在進步，每位患者的病情亦不盡相同；醫師應就病人之病情做個別特殊性的考量，病人和家屬亦應與醫師溝通討論，以決定最適當之診治方式。

自民國七十一年起，癌症已躍居為國人十大死因第一位。我國於民國九十二年公布施行「癌症防治法」，並依據該法衍生「國家癌症防治五年計畫」。為達成上述計畫訂定之目標，提升民眾對癌症防治之認識，本院於2004年11月正式成立癌症委員會，配合國民健康局之癌症防治中心計畫，積極推動癌症防治相關工作，提供癌症診療與癌症篩檢服務，以確保民眾之健康。

二、組織病理分類與分化

腺癌 (Adenocarcinoma) 佔所有病例的 90% 以上，次多的黏液性腺癌 (Mucinous adenocarcinoma)，及管性絨毛狀腺癌 (Adenocarcinoma in tubulovillous adenoma)，其餘其他型態如戒指細胞癌 (Signet ring cell carcinoma)、鱗狀細胞癌 (Squamous cell carcinoma)、腺鱗狀癌 (Adenosquamous carcinoma)、未分化癌 (Undifferentiated carcinoma) Papillary adenocarcinoma、Carcinoid tumor 等。

大腸直腸癌的病理組織分化分為：

1. 分化良好 (grade 1)
2. 分化中度 (grade 2)
3. 分化不良或未分化 (grade 3)
4. 分化無法評估 (grade x)

cTNM 是臨床分期，

pTNM 是病理分期；

前綴 y 用於接受新輔助治療後的腫瘤分期（如 ypTNM），病理學完全緩解的患者分期為 ypT0N0cM0，可能類似於 0 期或 1 期。

前綴 r 用於經治療獲得一段無瘤間期後復發的患者（rTNM）。

Tis 包括腫瘤細胞局限於腺體基底膜(上皮內)或黏膜固有層(黏膜內)，未穿過黏膜肌層到達黏膜下層。

T4 的直接侵犯包括穿透漿膜侵犯其他腸段，並得到鏡下診斷的證實(如盲腸癌侵犯乙狀結腸)，或者，位於腹膜後或腹膜下腸管的腫瘤，穿破腸壁固有基層後直接侵犯其他的臟器或結構，例如降結腸後壁的腫瘤侵犯左腎或側腹壁，或者中下段直腸癌侵犯前列腺、精囊腺、宮頸或陰道。腫瘤肉眼上與其他器官或結構粘連則分期為 cT4b。但是，若顯微鏡下該粘連處未見腫瘤存在則分期為 pT3。

V 和 L 亞分期用於表明是否存在血管和淋巴管浸潤，而 PN 則用以表示神經浸潤（可以是部位特異性的）。

三、分期表 (依照 AJCC 第 8 版 TNM 分期)

表 1. T、N、M 的定義

原發腫瘤 (T)	
Tx	原發腫瘤無法評估
T0	無原發腫瘤證據
Tis	原位癌：局限于上皮內或侵犯黏膜固有層
T1	腫瘤侵犯黏膜下層
T2	腫瘤侵犯固有肌層
T3	腫瘤穿透固有肌層到達漿膜下層，或侵犯無腹膜覆蓋的結直腸旁組織
T4a	腫瘤穿透腹膜臟層
T4b	腫瘤直接侵犯或粘連於其他器官或結構 c
區域淋巴結 (N)	
Nx	區域淋巴結無法評估
N0	無區域淋巴結轉移
N1	有 1-3 枚區域淋巴結轉移
N1a	有 1 枚區域淋巴結轉移
N1b	有 2-3 枚區域淋巴結轉移
N1c	漿膜下、腸系膜、無腹膜覆蓋結腸/直腸周圍組織內有腫瘤種植 (TD tumor deposit)，無區域淋巴結轉移
N2	有 4 枚以上區域淋巴結轉移
N2a	4-6 枚區域淋巴結轉移
N2b	7 顆及更多區域淋巴結轉移
遠處轉移 (M)	
Mx	遠處轉移無法評估
M0	無遠處轉移
M1	有遠處轉移
M1a	遠處轉移局限於單個器官或部位 (如肝、肺、卵巢、非區域淋巴結)
M1b	遠處轉移分佈於一個以上的器官/部位
M1c	腹膜表面轉移

表 2. 分期組合 (Anatomic stage/prognostic groups)

0	Tis	N0	M0
I	T1	N0	M0
	T2	N0	M0
IIA	T3	N0	M0
IIB	T4a	N0	M0
IIC	T4b	N0	M0
IIIA	T1-T2	N1/N1c	M0
	T1	N2a	M0
IIIB	T3-T4a	N1/N1c	M0
	T2-T3	N2a	M0
	T1-T2	N2b	M0
IIIC	T4a	N2a	M0
	T3-T4a	N2b	M0
	T4b	N1-N2	M0
IVA	Any T	Any N	M1a
IVB	Any T	Any N	M1b
IVC	Any T	Any T	M1c

四、直腸癌診療指引

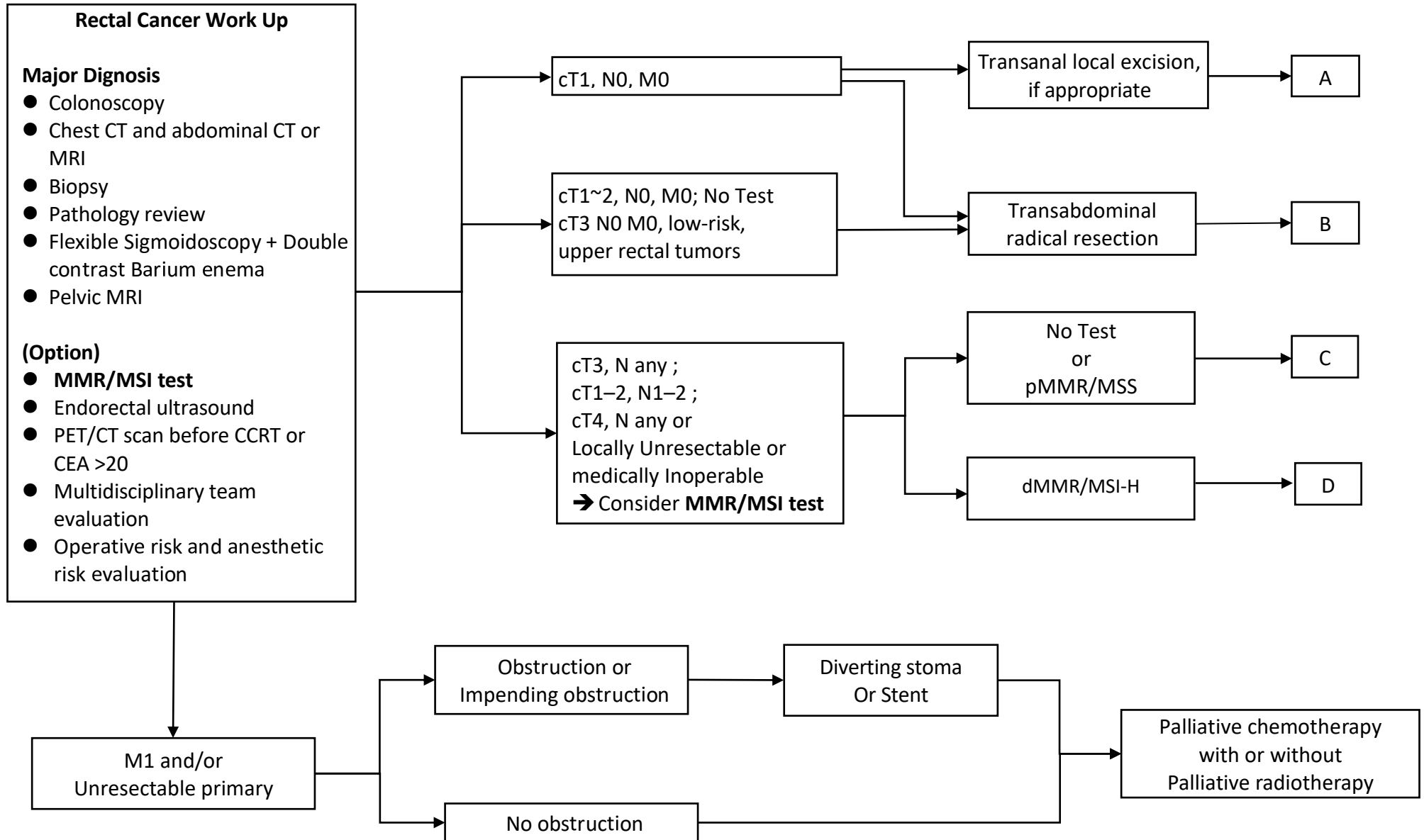

PATHOLOGIC FINDINGS

ADJUVANT TREATMENT
(UP TO 6 MO TOTAL PERIOPERATIVE TREATMENT)

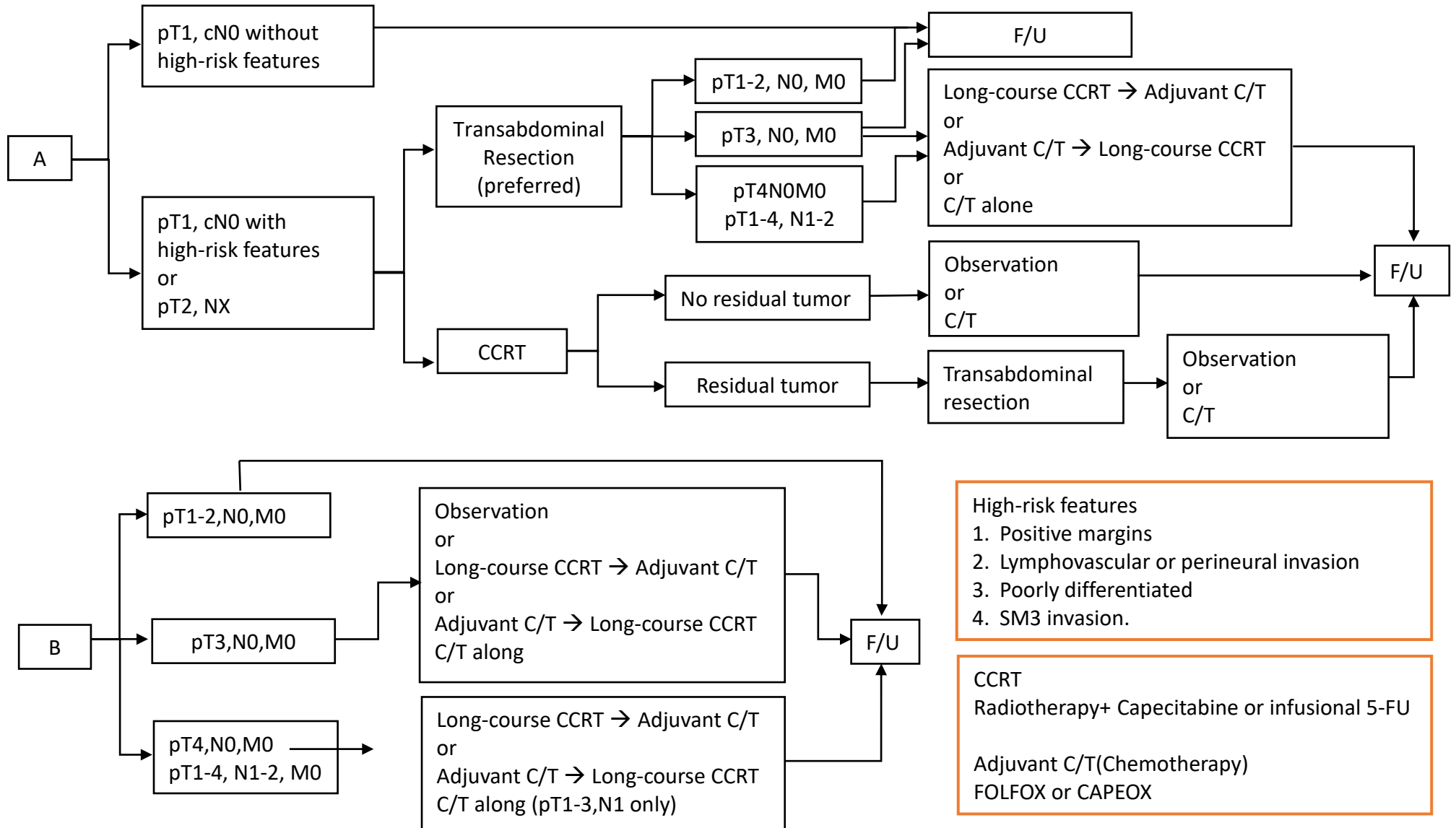

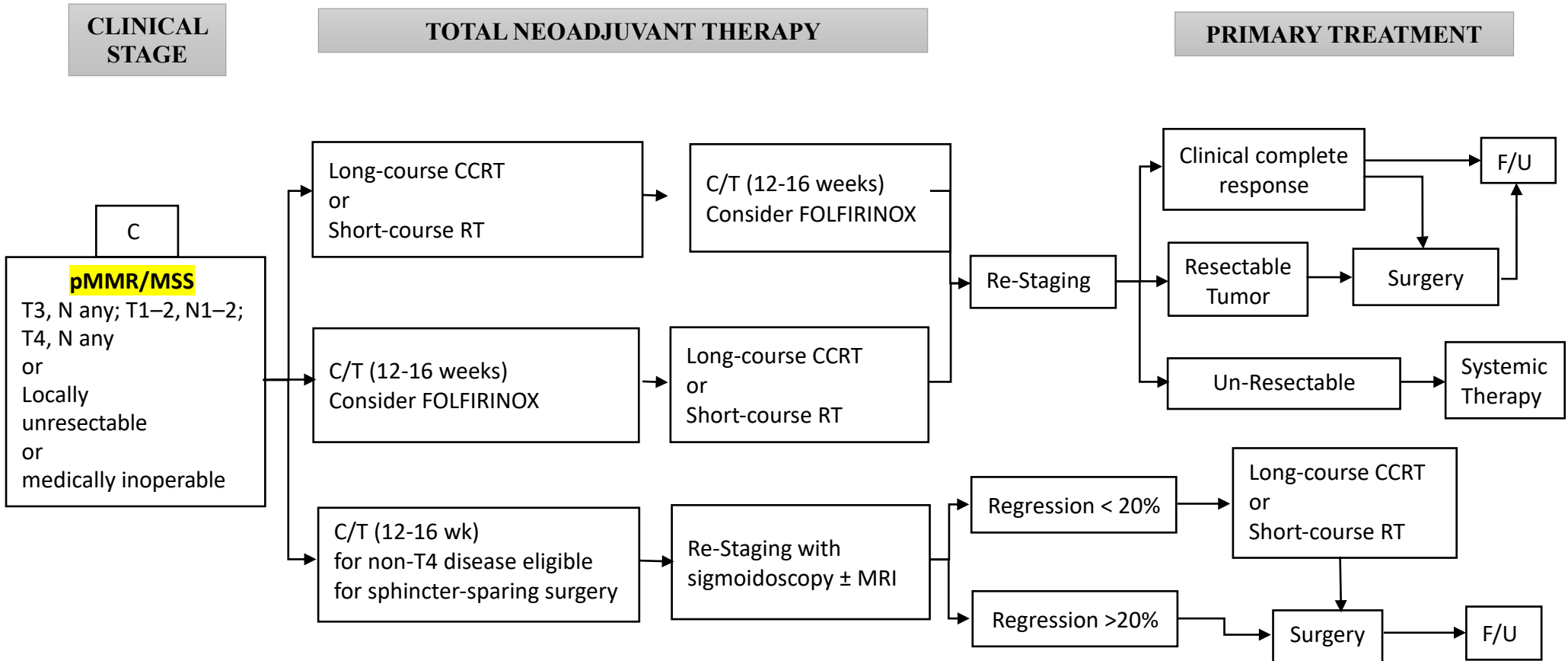

CCRT
Radiotherapy+ Capecitabine or infusional 5-FU or UFUR

C/T(Chemotherapy)
FOLFOX or CAPEOX or TegaFOX

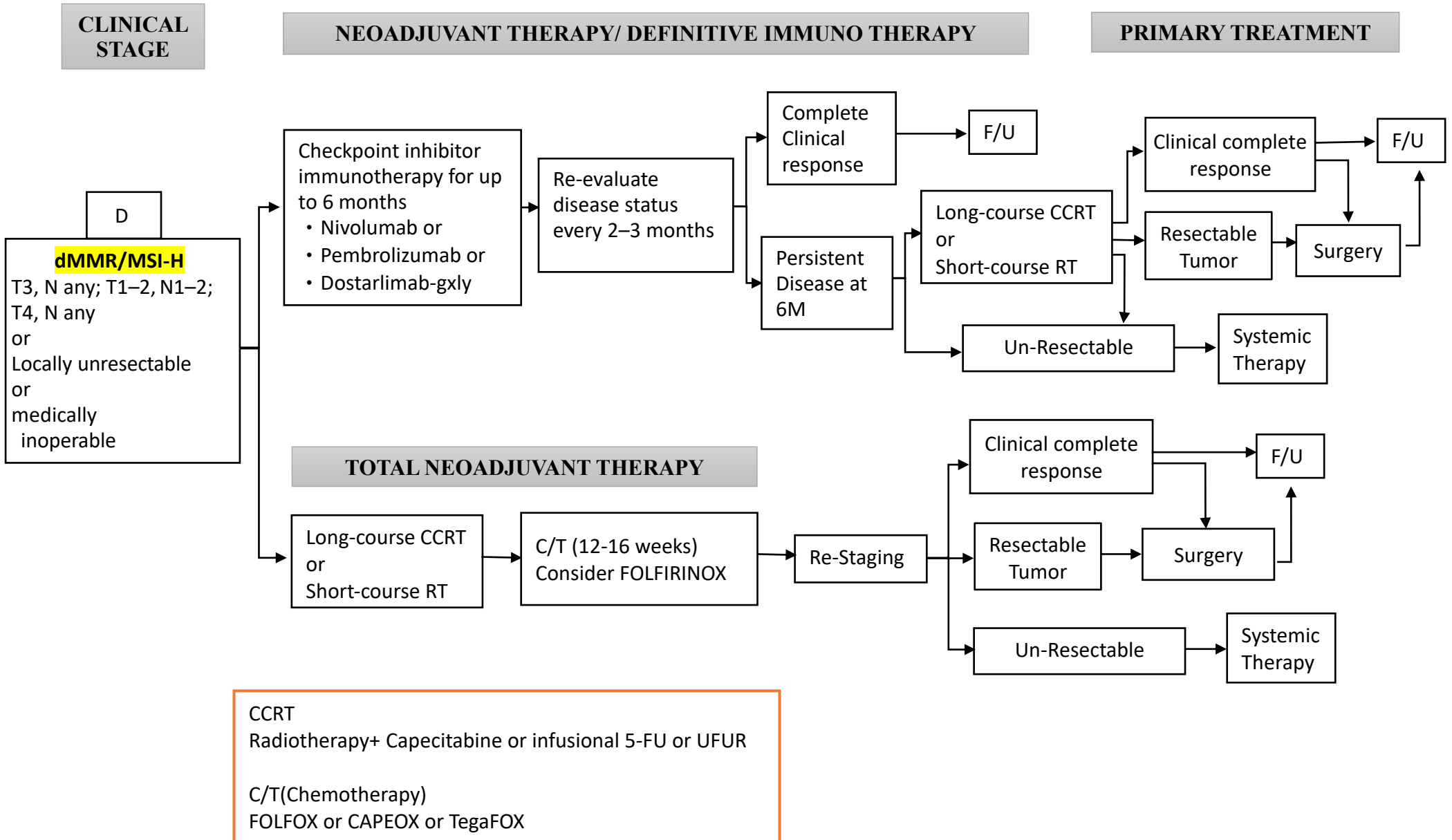

Follow Up

1. 病史詢問及身體檢查(含肛門指診)每 3 個月一次連續 2 年,然後每 6 個月一次連續 5 年.
2. CEA 每 3 個月檢測一次連續 2 年, 如果是 T2 以上每 6 個月,直到第 5 年.
3. Chest/abdominal /pelvic CT 每 3~6 個月一次 · 連續 5 年
4. 術後 1 年內做一次大腸鏡; 如果不正常則 1 年內再做一次, 或是如果沒有發現息肉則每 2-3 年做一次大腸鏡.
5. 如果術前是因為阻塞性病灶而沒有做大腸鏡,則術後 3 至 6 個月內做一次大腸鏡或直腸鏡加下消化道雙對比鋇劑攝影

五、化學治療處方 (Principles of chemotherapy)

1. Neoadjuvant chemoradiation for rectal cancer

Capecitabine

Capecitabine	750 - 825 mg/m ² po bid
7 days/week	

Krishnan S et al. Phase II study of capecitabine (Xeloda) and concurrent boost radiotherapy in patients with locally advanced rectal cancer. Int J Radiat Oncol Bio Phy 2006; 66:762.

Uracil-tegafur (UFT)

Uracil-tegafur	250 - 300 mg/m ² /day po
7 days/week	

C. H. Hsieh et al. Adjuvant CCRT for locally advanced rectal cancer: Uracil-tegafur? Or intravenous fluorouracil? J Clin Oncol 2006 ASCO Annual Meeting Proceedings; 24: 13584

XELOX

Capecitabine	825 mg/m ² po bid	d1-14
Oxaliplatin	50 mg/m ² iv	d1,14
Q2w		

Rodel C et al. Multicenter phase II trial of chemoradiation with oxaliplatin for rectal cancer. J Clin Oncol 2007; 25:110.

TagerOX

UFUR	250-300 mg/m ² /day po bid	14 days
Oxaliplatin	130 mg/m ² iv	d1
Q3w x 8 cycles		

2. Adjuvant chemotherapy

Uracil-Tegafur (UFUR)

Uracil-Tegafur	250-300 mg/m ² /day po bid
7 days/week x 1-2yrs	

Lembersky BC et al. Oral uracil and tegafur plus leucovorin compared with intravenous fluorouracil and leucovorin in stage II and III carcinoma of the



colon: results from national surgical adjuvant breast and bowel project protocol C-06. J Clin Oncol 2006; 24:2059

Capecitabine

Capecitabine	1000 - 1250 mg/m2 po bid	d1-8
daily x 6mos		

Twelves C et al. Capecitabine as adjuvant treatment for stage III colon cancer. N Engl J Med 2005; 352:2696.

Modified FOLFOX

Leucovorin	400 mg/m2 iv over 46 hrs	d1
5-FU	2400 -3000 mg/m2 iv over 46 hrs	d1
Oxaliplatin	85 mg/m2 iv	d1
Q2w x 12 cycles		

de Gramont A et al. Oxaliplatin/5FU/LV in adjuvant colon cancer: updated efficacy results of the MOSAIC trial, including survival, with a medium follow-up of six years. 2007 ASCO annual meeting. Abstract 4007

Tournigand, C et al. FOLFIRI followed by FOLFOX6 or the reverse sequence in advanced colorectal cancer: A randomized GERCOR study. J Clin Oncol 2004; 22:229

TagerOX

UFUR	250-300 mg/m2/day po bid	14 days
Oxaliplatin	130 mg/m2 iv	d1
Q3w x 8 cycles		

CapeOX

Capecitabine	850 – 1000 mg/m2 po bid	14 days
Oxaliplatin	130 mg/m2 iv	d1
Q3w x 8 cycles		

Schmoll H et al. Phase III trial of capecitabine plus oxaliplatin as adjuvant therapy for stage III colon cancer: a planned safety analysis in 1,864 patients. J Clin Oncol 2007; 25:102.

mHDFL

Leucovorin	400 mg/m2 iv 2 hrs	d1
5-FU	2400 -3000 mg/m2 iv over 46 hrs	d1
Q2 w x 12 cycles		

A de Gramont, et al. Randomized trial comparing monthly low dose leucovorin and fluorouracil bolus with bimonthly high dose leucovorin and fluorouracil bolus plus continuous infusion for advanced colorectal cancer: a French intergroup study. J Clin Oncol 1997; 1:808.

McCleary NJ, et al. Impact of older age on the efficacy of newer adjuvant therapies in >12,500 patients (pts) with stage II/III colon cancer: Findings from the ACCENT Database. J Clin Oncol 2009; 27:15s.

3. Chemotherapy for stage IV cancer

Modified FOLFOX

Leucovorin	150 mg/m² iv over 46 hrs	d1
5-FU	2400 -3000 mg/m² iv over 46 hrs	d1
Oxaliplatin	85 mg/m² iv	d1
q2w		

Tournigand, C et al. FOLFIRI followed by FOLFOX6 or the reverse sequence in advanced colorectal cancer: A randomized GERCOR study. J Clin Oncol 2004; 22:229

FOLFIRI

Leucovorin	400 mg/m² iv over 2 hrs before 5-FU	d1
5-FU	400 mg/m² iv bolus d1, and then 2400 - 3000 mg/m² iv over 46 hrs	d1
Irinotecan	150 - 180 mg/m² iv	d1
q2w		

Modified FOLFIRI

Leucovorin	400 mg/m² iv over 46 hrs	d1
5-FU	2400 - 3000 mg/m² iv over 46 hrs	d1
Irinotecan	150 - 180 mg/m² iv	d1
q2w		

Fuchs CS et al. Randomized, controlled trial of irinotecan plus infusional, bolus, or oral fluoropyrimidines in first-line treatment of metastatic colorectal cancer: results from the BICC-C study. J Clin Oncol 2007; 25:4779.

Van Cutsem E et al. Randomized phase III study of irinotecan and 5-FU/FA with or without cetuximab in the first-line treatment of patients with metastatic colorectal cancer (mCRC): The CRYSTAL trial. 2007 ASCO annual meeting. Abstract 4000.

CapeOX

Capecitabine	850 - 1000 mg/m² po bid	d1-14
Oxaliplatin	50 - 70 mg/m² iv	d1, 8
q3w		

Mayer RJ et al. Should capecitabine replace infusional fluorouracil and leucovorin when combined with oxaliplatin in metastatic colorectal cancer



(Editorial). J Clin Oncol 2007; 25:4165.

Porschen R et al. Phase III study of capecitabine plus oxaliplatin compared with fluorouracil and leucovorin plus oxaliplatin in metastatic colorectal cancer: a final report of the AIO Colorectal Study Group. J Clin Oncol 2007; 25:4217.

Capecitabine

Capecitabine	1000-1250 mg/m2 po bid	14 days
q3w till disease progression		

Van Cutsem, E et al. Oral capecitabine compared with intravenous fluorouracil plus leucovorin in patients with metastatic colorectal cancer: Results of a large phase III study. J Clin Oncol 2001; 19:4097.

Modified Uracil-Tegafur

Uracil-Tegafur	250 - 300 mg/m2/day
7 days/week	

Hochster HS et al. Phase II study of uracil-tegafur with leucovorin in elderly (> 75 years old) patients with colorectal cancer: ECOG 1299. J Clin Oncol 2007; 25:5397.

Irinotecan

Irenotecan	125mg/m2	d1, 8
Q3w		

Fuchs CS et al. Phase III comparison of two irinotecan dosing regimens in second-line therapy of metastatic colorectal cancer. J Clin Oncol 2003; 21:807.

FOLFIRINOX

Irenotecan	150-165→mg/m2	60 min	d1
Oxaliplatin	85→ mg/m2 iv		d1
Leucovorin	200 mg/m2 iv over 46 hrs		d1
5-FU	3200→mg/m2 iv over 48hrs		d1
Q2w			

FOLFIRINOX is recommended instead of FOLFOXIRI because FOLFOXIRI uses a high dose of fluorouracil (3,200 mg/m² over 48 hours). Patients in the United States (U.S.) have been shown to have greater toxicity with fluorouracil. The dose of fluorouracil (2,400 mg/m² over 46 hours) is a starting dose consistent with the dose recommended in FOLFOX or FOLFIRI and should be strongly considered for U.S. patients.

註:依病人狀況調整劑量

Modified FOLFIRINOX

Irenotecan	150mg/m2 30-90 min	d1
Oxaliplatin	85mg/m2 iv	d1
Leucovorin	400mg/m2 iv over 2hours	d1
5-FU	2400mg/m2 iv over 46-48hrs	d1
Q2w		

Bennouna J, Andre T, Campion L, et al. Rationale and design of the IROCAS study: multicenter, international, randomized phase 3 trial comparing adjuvant modified (m) FOLFIRINOX to mFOLFOX6 in patients with high-risk stage III (pT4 and/or N2) colon cancer-A UNICANCER GI-PRODIGE Trial. Clin Colorectal Cancer 2019;18:e69-e73.

Lamarca A, Foster L, Valle J, et al. FOLFIRINOX or FOLFOXIRI in locally advanced duodenal adenocarcinoma: are we missing out? ESMO Open 2020;5:e000633.

Broquet A, Bachet JB, Huguier F, et al. NORAD01-GRECCAR16 multicenter phase III non-inferiority randomized trial comparing preoperative modified FOLFIRINOX without irradiation to radiochemotherapy for resectable locally advanced rectal cancer (intergroup FRENCH-GRECCAR-PRODIGE trial). BMC Cancer 2020;20:485.

註:依病人狀況調整劑量

4.Target therapy for stage IV cancer

Bevacizumab + chemotherapy

Bevacizumab	5 mg/kg iv	d1
q2w		

Phase II, randomized trial comparing bevacizumab plus fluorouracil (FU)/leucovorin (LV) with FU/LV alone in patients with metastatic colorectal cancer. J Clin Oncol 2003; 21:60

Saltz LB et al. Bevacizumab (Bev) in combination with XELOX or FOLFOX4: efficacy results from XELOX-1/No 16966, a randomized phase III trial in the first-line treatment of metastatic colorectal cancer (MCRC). 2007 Gastrointestinal Cancers Symposium. Abstract 238.

Giantonio, BJ et al. Bevacizumab in combination with oxaliplatin, fluorouracil, and leucovorin (FOLFOX4) for previously treated metastatic colorectal cancer: Results from the Eastern Cooperative Oncology Group Study E3200. J Clin Oncol 2007; 25:1539.

Hurwitz, H et al. Bevacizumab plus irinotecan, fluorouracil, and leucovorin for metastatic colorectal cancer. N Engl J Med 2004; 350:2335.

Cetuximab +/- chemotherapy (for patients with wild-type KRAS)

Cetuximab	400 mg/m2 iv d1, and then 500 mg/m2 iv over 1 hour
q2w	

Bokemeyer C et al. KRAS status and efficacy of first-line treatment of patients with metastatic colorectal cancer (mCRC) with FOLFOX with or without cetuximab: the OPUS experience. 2008 ASCO annual meeting. Abstract 4000.

Van Cutsem E et al. KRAS status and efficacy in the first-line treatment of patients with metastatic colorectal cancer (mCRC) treated with or without cetuximab: the CRYSTAL experience. 2008 ASCO annual meeting. Abstract 2.

Jonker DJ et al. Cetuximab for the treatment of colorectal cancer. N Engl J Med 2007; 357-2040.



Sobrero AF et al. EPIC: phase III trial of cetuximab plus irinotecan after fluoropyrimidine and oxaliplatin failure in patients with metastatic colorectal cancer. J Clin Oncol 2008; 26:2311.

ZALTRAP +/- chemotherapy

Target therapy(Optional) 自費 ZALTRAP	4 mg/kg iv over 1 hour
	q2w

Target therapy(Optional)	STIVARGA (regorafenib) 400 mg/m ² x4 po QD
	21 days/cycle

Panitumumab(Vectibix) +/- chemotherapy (KRAS/NRAS/BRAF WT only)

Panitumumab	6 mg/kg IV over 60 minutes	d1
		q2w

- 1.建議劑量:6 mg/kg，每兩週一次。
- 2.與 FOLFOX 合併使用於治療 K-RAS 基因及 N-RAS 基因沒有突變之轉移性直腸結腸病患之第一線治療。
- 3.本藥品需事前審查核准後使用，每次申請事前審查之療程以 12 週為限，再次申請必須提出客觀證據(如:影像學)證實無惡化，才可繼續使用。
- 4.使用總療程以 24 週為上限。
5. Panitumumab(Vectibix)+ FOLFOX 與 ErbituxFOLFIRI 二者僅能擇依使用。微有再無法忍受化療(其副作用)時方可交換。

Nivolumab (dMMR/MSI-H only)

Nivolumab	3 mg/kg	d1
Nivolumab	240 mg iv	d1
Nivolumab	480 mg iv	d1
		q2w

Pfeiffer PP, Yilmaz M, Moller S, et al. TAS-102 with or without bevacizumab in patients with chemorefractory metastatic colorectal cancer: an investigator-initiated, open-label, randomised, phase 2 trial. Lancet Oncol 2020;21:412-420.

Nivolumab+ ipilimumab (dMMR/MSI-H only)

Nivolumab	3 mg/kg (30-minute IV infusion)	d1
Ipilimumab	1 mg/kg (30-minute IV infusion)	d1



q3w

Overman MJ, Lonardi S, Wong K et al. Durable clinical benefit with nivolumab plus ipilimumab in DNA mismatch repair–deficient/microsatellite instability–high metastatic colorectal cancer. *J Clin Oncol* 2018;36:773-779.

Pembrolizumab (dMMR/MSI-H only)

Pembrolizumab	2 mg/kg IV	every 3 weeks
Pembrolizumab	200 mg IV	every 3 weeks
Pembrolizumab	400 mg IV	every 6 weeks

Le DT, Uram JN, Wang H, et al. PD-1 blockade in tumors with mismatch-repair deficiency. *N Engl J Med* 2015;372:2509-2520.

Encorafenib + cetuximab(BRAF V600E mutation positive)

Encorafenib	300mg/kg	daily
Cetuximab	400 mg/m ² IV followed by 250 mg/m ² IV	weekly
Cetuximab	500 mg/m ² IV	every 2 weeks

Van Cutsem E, Huijberts S, Grothey A, et al. Binimetinib, encorafenib, and cetuximab triplet therapy for patients with *BRAF* V600E-mutant metastatic colorectal cancer: Safety lead-in results from the phase III BEACON Colorectal Cancer Study. *J Clin Oncol* 2019;37:1460- 1469.

Kopetz S, Grothey A, Yaeger R, et al. Encorafenib, Binimetinib, and Cetuximab in *BRAF* V600E-Mutated Colorectal Cancer. *N Engl J Med*. 2019;381:1632-1643.

Kopetz S, Grothey A, Van Cutsem E, et al. Quality of life with encorafenib plus cetuximab with or without binimetinib treatment in patients with *BRAF* V600E-mutant metastatic colorectal cancer: patient-reported outcomes from BEACON CRC. *ESMO Open* 2022;7:100477.

Encorafenib + panitumumab (BRAF V600E mutation positive)

Encorafenib	300mg/kg po	daily
Panitumumab	6 mg/kg IV	
q2W		

Kopetz S, Grothey A, Van Cutsem E, et al. Quality of life with encorafenib plus cetuximab with or without binimetinib treatment in patients with *BRAF* V600E-mutant metastatic colorectal cancer: patient-reported outcomes from BEACON CRC. *ESMO Open* 2022;7:100477.

Sotorasib + cetuximab (KRAS G12C mutation positive)

Sotorasib	960 mg PO	daily
Cetuximab	500mg/m ² IV	
q2W		

Kuboki Y, Yaeger R, Fakih MG, et al. Sotorasib in combination with panitumumab in refractory *KRAS* G12C-mutated colorectal cancer: Safety and efficacy for phase Ib full expansion cohort. *Ann Oncol* 2022;33:S136-S196.

Sotorasib + panitumumab (KRAS G12C mutation positive)

Sotorasib	960 mg PO	daily
-----------	-----------	-------



Panitumumab	6mg/kg IV
q2W	



六、放射線治療 (Principles of radiation)

(一)、放射治療的適應症

1. 若屬於T2，只進行局部切除(local excision)應考慮輔助性合併化學放射治療(post-operative adjuvant CCRT)。
2. 第II及III期並可局部切除可進行手術前進行合併化學放射治療 (pre-operative CCRT)，或在手術後進行輔助性合併化學放射治療 (post-operative adjuvant CCRT)。
3. 第III期 (T4或局部無法切除)可考慮同步化學放射治療 (CCRT)、或對腫瘤局部區域進行近接治療 (brachytherapy)。

(二)、放射治療技術

A. 劑量給予：

1. 建議療程應以標準分次進行(每日一次、每週五次)。
2. 若手術前放射治療，劑量應為50-60 Gy / 25~28分次
3. 若手術後放射治療，給予劑量應為45.0~50.4 Gy / 25~28分次
4. 腫瘤部位(GTV)劑量為50~60 Gy/25~30次
5. 骨盆腔淋巴結劑量為45~50.4 Gy/25~28次
6. GTV包含主要原發腫瘤及轉移性淋巴結，範圍由理學檢查、內視鏡檢查、影像學檢查、和放射治療模擬定位決定
7. CTV包含GTV和腫瘤及淋巴結周圍可能有顯微細胞侵犯的區域
8. 對於可切除的腫瘤，照射45 Gy之後，應考慮瘤床和邊緣2cm範圍予追加劑量。追加劑量為5~15Gy。
9. 對於不可切除的腫瘤，放療劑量應高於54 Gy。
10. 短療程放射線治療(25Gy/5次)可被採用於術前照射
11. 有風險的淋巴結區域包含直腸周圍淋巴結區、骶前淋巴結、髂內淋巴結。
12. T4腫瘤侵犯前方結構時需照射髂外淋巴結。



13. 使用躺臥的姿勢、脹尿、和其他照射技巧，儘量減少照射野內的小腸。
14. 對於接受腹會陰聯合切除術後患者照射野應包括會陰切口皮膚。
15. 對於曾經治療過又復發的病人，需要再次接受放療時，IMRT是較好的選擇。IMRT也是術後放療有發生急性或晚期副作用的病人，和腫瘤位於特殊解剖位置(涵蓋外側股動靜脈區淋巴結、鼠蹊部淋巴結或是避開小腸的區域)較合適的選擇。
16. 接受過骨盆腔照射後局部復發的病人，再次作治療計畫時可考慮使用hyperfractionated骨盆腔照射治療。
17. 對於術後margin close 或是margin positive的病人，特別是T4或腫瘤復發時，可以考慮使用IORT追加劑量(additional boost)。

B. 基本原則

1. 放療期間應同期使用口服或持續靜脈注射以Fluoropyrimidine為基礎的化療。
2. 病人如果有有限數量的肝和肺轉移，在嚴格篩選病人後，或是參與臨床試驗的狀況下，可以考慮針對轉移部位做根除性ablative放療。
3. 以高度順形的方式給予。技術包含3D conformal RT, IMRT或是SBRT。
4. 可以使用kilovoltage(kV)或是cone beam CT的影像導引的放療(IGRT)

C. 最高劑量限制：

1. 小腸：50 Gy
2. 股骨頭：42 Gy
3. 膀胱：65 Gy
4. 直腸：60 Gy

D. 合併症：

1. 急性：腹瀉、排尿困難、疲倦、皮膚紅腫、血球數下降。
2. 慢性：排便習慣改變、腹瀉、小腸阻塞。



八、手術治療原則

@經肛切除：

● 標準

佔據腸腔小於30%	T1或T2 (T2腫瘤需警惕高復發風險)
腫瘤直徑< 2.5 cm	切除息肉伴癌浸潤，或病理學不確定
切緣陰性 (距離腫瘤大於3 mm)	無血管淋巴管浸潤 (LVI) 或神經周圍浸潤
活動，不固定	高~中分化
距肛緣8 cm以內	治療前無淋巴結腫大的影像學證據

- 如果能在直腸內充分顯露腫瘤，可考慮經肛門顯微手術 Transanal endoscopic microsurgery (TEM) or Transanal minimally invasive surgery (TAMIS)。

@經腹切除：腹部會陰聯合切除術或低位前切除術或全直腸系膜切除 (TME) +結腸肛管吻合。

● 治療原則

主刀醫生應在手術前確定腫瘤下緣，並熟習TME手術及腫瘤的淋巴引流區域

Neoadjuvant therapy 及手術前應以MRI評估環周切緣Circumferential margins (CRM)

保證足夠切緣(CRM 及遠端切緣)

● TME

減少CRM的陽性率。切除腫瘤下緣以下4~5 cm的直腸系膜才算足夠。下段直腸癌 (距離肛緣小於5 cm) 切除腫瘤遠端腸管1~2 cm是可以接受的，但需術中冰凍病理檢查證實切緣陰性。游離全部直腸可保證遠切緣陰性並切除足夠直腸系膜。

● 淋巴結清掃

盡可能把清掃範圍外的可疑淋巴結切除。

如果無臨床可疑轉移的淋巴結，不推薦擴大的淋巴結清除術。

@ 病理評估原則

內鏡下切除的惡性息肉：

- 惡性息肉是指息肉中有癌細胞浸潤穿透粘膜肌層到達粘膜下層（pT1）。pTis不屬於“惡性息肉”。
- 良好的組織學特徵包括：1或2級分化，無血管、淋巴管浸潤，切緣陰性。目前尚無對切緣陽性的統一定義。其定義包括：(1)腫瘤距切緣小於1 mm；(2)腫瘤距切緣小於2 mm；(3)切緣可見癌細胞。
- 不良的組織學特徵包括：3或4級分化，或血管、淋巴管浸潤，或“切緣陽性”。切緣陽性的定義見上述。
- 結直腸惡性廣基息肉能否通過內鏡下切除獲得成功治療，目前尚有爭議。文獻似乎認為與帶蒂惡性息肉相比，廣基惡性息肉內鏡下切除後，不良預後事件（如腫瘤殘留、腫瘤復發、死亡、血行轉移，但不包括淋巴結轉移）的發生率更高。息肉的外形本身並不是預後不良的一個很有意義的參數，那些細胞分化1或2級、切緣陰性、無血管、淋巴管浸潤的惡性廣基息肉，能夠通過內鏡下切除獲得成功治療。

經肛切除：

- 良好的組織病理學特徵包括：小於3 cm，T1或T2（T2需謹慎，因復發率高），1或2級分化，無血管、淋巴管浸潤，切緣陰性。
- 不良的組織病理學特徵包括：大於3 cm，T1或T2，3級分化，或血管、淋巴管浸潤，或切緣陽性。

病理學分期：

- 病理報告中應該包括：

腫瘤分化程度:腫瘤浸潤深度（T），T分期是根據有活力的腫瘤細胞來決定的，經過新輔助治療的標本內無細胞的粘液湖不認為是腫瘤殘留。檢出淋巴結個數和陽性淋巴結數（N），經過新輔助治療的標本內無細胞的粘液湖不認為是腫瘤殘留。

近端、遠端和環周切緣的情況。環周切緣（CRM）陽性的定義是腫瘤距切緣小於1 mm或2 mm。

淋巴結評估：AJCC和美國病理學家協會（CAP）建議至少需送檢12顆淋巴結才能準確判斷為II期結直腸癌。但是文獻報導的診斷II期結直腸癌所需的淋巴結送檢最低數目要求常不統一，分別有大於7顆、大於9顆、大於13顆、大於20顆、大於30顆。這些研究多數將結腸癌和直腸癌混合在一起分析，而且未經新輔助治療，初始治療即為手術。有2項只限於直腸癌的研究指出至少檢出14顆和大於10顆淋巴結才能準確判斷為II期直腸癌。淋巴結檢出數目跟患者年齡、性別、腫瘤分化程度和部位有關。對II期結腸癌（pN0），如果初始檢查不能找到12顆淋巴



結，推薦病理醫生應該重新解剖標本，重新送檢更多的疑似淋巴結的組織。如果最終還是找不夠12顆淋巴結，應在報告上加注評論，表明已經盡力解剖淋巴結。接受過新輔助治療的直腸癌患者平均淋巴結檢出數目明顯少於直接手術患者（13 vs 19, $P < 0.05$, 7 vs 10, $P < 0.001$ ）。如果以12顆淋巴結作為II期腫瘤的準確分期標準的話，接受過新輔助治療的患者只有20%能夠檢出足夠的淋巴結。接受過新輔助治療患者要準確分期所需的淋巴結數目目前仍不清楚。然而準確分期的意義有多大仍屬未知，因為接受過新輔助治療的患者無論手術後病理分期如何都需要接受術後輔助治療。

KRAS NRAS, and BRAF突變檢測

- 所有治療轉移性結直腸癌應該有腫瘤組織進行基因分型的RAS突變（KRAS和NRAS）。患者與任何已知的KRAS基因突變（外顯子2或無外顯子2）或NRAS突變不應與任何西妥昔單抗或panitumumab.48,49,50處理
- 患者中的V600E BRAF突變似乎具有更差的預後。沒有足夠的數據來指導使用抗EGFR治療的基礎上BRAF V600E突變狀態的一線設置有積極化療。有限的可用數據表明缺乏從在V600E突變的存在抗EGFR單克隆抗體的抗腫瘤活性的使用時，後一個患者進展一線therapy.51,53
- 測試進行KRAS，NRAS，和BRAF突變只應在被下的1988（CLIA-88）的臨床實驗室改進修正案為合格認證的執行高度複雜的臨床實驗室（分子病理學）檢測實驗室中進行。
- 該測試可以對福爾馬林固定，石蠟包埋的組織進行。該測試可以在主結腸直腸癌和/或轉移被執行，如文獻表明，KRAS，NRAS，和BRAF突變是在兩個試樣types.53類似

直腸系膜（TME術後）的評價

- 對位於直腸遠端2/3的中低位直腸癌，病理醫生應評價TME手術的品質（直腸系膜的完整性）。

直腸癌的外科治療仍然是治療的最主要手段，但如果僅僅強調手術而沒有合理地結合放化療，將不能最大限度提高治療效果。

NCCN直腸癌治療指南的適應範圍是指硬管直腸鏡測定的距肛12cm的大腸。因為距肛12 cm以上直腸的解剖學特點、復發轉移的規律、治療方式的選擇與結腸是不同的。

術前分期很重要

制定直腸癌治療方案的基礎是術前分期。直腸癌的術前分期遠較結腸癌重要，這主要是因為直腸癌治療中輔助放化療價值已獲得了明確證據，成為部分直腸癌治療的金標準，如果沒有術前分期就無法確定新輔助治療。

病理報告強調三項重點

要求常規檢查淋巴結數 > 12顆

強調報告環周切緣狀態(CRM)

全直腸系膜切除 (TME) 是直腸癌手術切除的標準

要求常規檢查淋巴結數 > 12顆

直腸癌的病理檢查除了常規腫瘤臨床病理分期外，淋巴結檢測數也倍受關注，因為淋巴結的檢測數可以反映手術切除和清掃的範圍以及病理檢查的規範度。尤其對 I、II 期直腸癌患者，淋巴結的檢測數更為重要，在是否進行輔助治療上具有決定性意義。要求常規檢查淋巴結數超過 12 顆。總體來講，直腸癌淋巴結數少於結腸癌，而放化療後的淋巴結數往往更少。

強調報告環周切緣狀態(CRM)

在對腫瘤切緣的報告要求中，除了對過去所強調的遠、近切緣要求常規報告外，還突出強調了環周（放射狀）切緣狀態報告的重要性。環周切緣（CRM）陽性的定義為切緣 < 1 mm 或 < 2 mm。環周切緣與腫瘤局部復發和預後明顯相關，是最重要的預後因素之一。

要求報告反映 TME 滿意度情況

全直腸系膜切除 (TME) 是直腸癌手術切除的標準，TME 滿意度情況在病理上分為 3 級：不完整的 TME 切除、近完整的 TME 切除和完整的 TME 切除。完整的直腸系膜，表面光滑，環行外緣是光滑的。TME 滿意度情況的準確報告有助於指導治療、判斷預後。

@ 外科治療的建議與“不”建議

1. 肛門保留取決於腫瘤分期和腫瘤下緣至齒狀線的距離
2. 不建議常規行擴大淋巴結清掃術
3. 局部切除應綜合考慮，慎重選擇
4. 要求直腸癌手術的主刀醫生必須親自進行直腸鏡檢查並進行分期，瞭解腫瘤分期和腫瘤下緣至齒狀線的距離，這是真正決定能否肛門

保留的可靠依據。

5. 不建議常規行擴大淋巴結清掃術
6. 除非臨床懷疑有側方淋巴結轉移，不建議常規行擴大淋巴結清掃術。

@ 局部切除應綜合考慮，慎重選擇

對於早期（T1/T2）低位直腸癌，局部切除可作為根治性手段之一。

@ 局部切除病例的選擇標準：腫瘤占腸周徑<30%、腫瘤<3 cm、切緣距腫瘤>3 mm、腫瘤距肛門<8 cm、T1或T2期、無淋巴管血管或神經受侵、中高分化及術前檢查無明確的淋巴結轉移等。對T2期腫瘤選擇局部切除時應非常謹慎，因其具有較高的局部復發率。

@ 輔助治療界限分明

1. 以距肛門12 cm為界區分輔助治療方法
2. 直腸癌輔助治療中最重要的一點是以距肛緣12 cm為界區分治療，距肛緣12 cm以上直腸癌的輔助治療與結腸癌相同；而肛緣12 cm以下直腸癌的輔助治療是新輔助放化療和輔助放化療。
3. 推薦放化療相結合的輔助或新輔助治療
4. 放療和（或）放化療在直腸癌治療中佔有重要地位，術前新輔助放療或放化療在局部晚期直腸癌中的應用越來越廣泛。有III期臨床試驗表明，聯合5-Fu為主的放化療能進一步提高T3~4期腫瘤放療有效率，因此推薦在新輔助治療和輔助治療時採用放化療結合的綜合治療，而不是採用單純放療。對T3~4期局部晚期直腸癌，推薦在條件允許的情況下，採用術前新輔助放化療作為標準治療方案。對T3N0和TNN1~2期直腸癌，僅在有術前多科治療禁忌證時考慮直接手術治療。建議盡可能在新輔助放化療後5~10周考慮手術切除，以增加肛門保留機率、減少手術困難。手術切除後不論病理結果如何均應進行輔助化療。對於未進行新輔助放化療的患者，如術後病理為T3~4或N+均應進行輔助放化療，以減少局部復發。

@ 直腸癌肝轉移的治療

A: 在保留足夠肝臟的前提下儘量達到切緣陰性



肝臟是結直腸癌最易發生轉移的部位之一。選擇合適的患者行肝轉移灶切除是提高IV期結直腸癌療效的最主要措施之一。對根治性肝轉移灶切除的治療上重點強調在保留足夠殘餘肝臟的前提下，盡可能達到切緣陰性。肝轉移灶切除是以根治性切除為目標，因此不推薦轉移灶部分切除，同時強調爭取治癒性切除。對適合手術切除患者不推薦選擇射頻消融治療(RFA)，但可以與手術切除治療結合；肝動脈栓塞治療(TAE)僅適用於臨床試驗。

B: 不可切除肝轉移分為潛在可切除或不可切除的肝轉移

因為完全不可切除的肝轉移可以按照一般晚期腫瘤處理原則進行；而潛在可切除的肝轉移多數可通過積極的新輔助化療而獲得切除的可能。所以對潛在可切除的肝轉移，要用最積極的新輔助化療，如化療聯合標靶藥物治療或三藥聯合化療，以最大限度地爭取肝轉移的切除。



九、實證醫學

Categories of Evidence and Consensus :

Category 1: There is uniform NCCN consensus, based on high-level evidence, that the recommendation is appropriate.

Category 2A: There is uniform NCCN consensus, based on lower- level evidence including clinical experience, that the recommendation is appropriate.

Category 2B: There is nonuniform NCCN consensus (but no major disagreement), based on lower-level evidence including clinical experience, that the recommendation is appropriate.

Category 3: There is major NCCN disagreement that the recommendation is appropriate.

All recommendations are category 2A unless otherwise noted.

NCCN 對證據和共識的分類

1 類：基於高水準證據（如隨機對照試驗）提出的建議，專家組一致同意。

2A 類：基於低水準證據提出的建議，專家組一致同意。

2B 類：基於低水準證據提出的建議，專家組基本同意，無明顯分歧。

3 類：基於任何水準證據提出的建議，專家組意見存在明顯的分歧。

除非特別指出，NCCN 對所有建議均達成 2A 類共識。

十、安寧緩和照護原則

若預期疾病難以治癒時，病人存活期小於 6 個月便適合安寧療護(Pomeranz & Brustman, 2005；Waldrop & Rinfrette, 2009)。

若藉由症狀、檢驗數據、及確切的腫瘤診斷，證實臨床上該惡性腫瘤已經廣泛侵犯、或進展快速；功能分數（Palliative Performance Scale）低於 70%；拒絕進一步腫瘤治癒性治療，或者在治療之下仍持續惡化者，即可轉介緩和醫療團隊（彭等，2006）。

十一、參考文獻

1. NCCN guideline 2023.v.5 版

2. 彭仁奎、邱泰源、陳慶餘 (2006) , 老年緩和醫療簡介, 安寧療護雜誌 11(3) ,
273-284

3. Krishnan S et al. Phase II study of capecitabine (Xeloda) and concurrent boost radiotherapy in patients with locally advanced rectal cancer. Int J Radiat Oncol Bio Phy 2006; 66:762.

4. C. H. Hsieh et al. Adjuvant CCRT for locally advanced rectal cancer: Uracil-tegafur? Or intravenous fluorouracil? J Clin Oncol 2006 ASCO Annual Meeting Proceedings; 24: 13584

5. Ryan DP et al. Phase I/II study of preoperative oxaliplatin, fluorouracil, and external-beam radiation therapy in patients with locally advanced rectal cancer: Cancer and Leukemia Group B 89901. J Clin Oncol 2006; 24:2557.

6. Lembersky BC et al. Oral uracil and tegafur plus leucovorin compared with intravenous fluorouracil and leucovorin in stage II and III carcinoma of the colon: results from national surgical adjuvant breast and bowel project protocol C-06. J Clin Oncol 2006; 24:2059

7. Twelves C et al. Capecitabine as adjuvant treatment for stage III colon cancer. N Engl J Med 2005; 352:2696.

8. de Gramont A et al. Oxaliplatin/5FU/LV in adjuvant colon cancer: updated efficacy results of the MOSAIC trial, including survival, with a medium follow-up of six years. 2007 ASCO annual meeting. Abstract 4007
Tournigand, C et al. FOLFIRI followed by FOLFOX6 or the reverse sequence in advanced colorectal cancer: A randomized GERCOR study. J Clin Oncol 2004; 22:229

9. Schmoll H et al. Phase III trial of capecitabine plus oxaliplatin as adjuvant therapy for stage III colon cancer: a planned safety analysis in 1,864 patients. J Clin Oncol 2007; 25:102.

10. A de Gramont, et al. Randomized trial comparing monthly low dose leucovorin and fluorouracil bolus with bimonthly high dose leucovorin and fluorouracil bolus plus continuous infusion for advanced colorectal cancer: a French intergroup study. J Clin Oncol 1997; 1:808.

McCleary NJ, et al. Impact of older age on the efficacy of newer adjuvant therapies in >12,500 patients (pts) with stage II/III colon cancer: Findings from the ACCENT Database. J Clin Oncol 2009; 27:15s.

11. Tournigand, C et al. FOLFIRI followed by FOLFOX6 or the reverse sequence in advanced colorectal cancer: A randomized GERCOR study. J Clin Oncol 2004; 22:229

12. Porschen R et al. Phase III study of capecitabine plus oxaliplatin compared with fluorouracil and leucovorin plus oxaliplatin in metastatic colorectal cancer: a final report of the AIO Colorectal Study Group. J Clin Oncol 2007; 25:4217

13. Fuchs CS et al. Randomized, controlled trial of irinotecan plus infusional, bolus, or oral fluoropyrimidines in first-line treatment of metastatic colorectal cancer: results from the BICC-C study. J Clin Oncol 2007; 25:4779.

Van Cutsem E et al. Randomized phase III study of irinotecan and 5-FU/FA with or without cetuximab in the first-line treatment of patients with metastatic colorectal cancer (mCRC): The CRYSTAL trial. 2007 ASCO annual meeting. Abstract 4000.

14. Mayer RJ et al. Should capecitabine replace infusional fluorouracil and leucovorin when combined with oxaliplatin in metastatic colorectal cancer



- (Editorial). *J Clin Oncol* 2007; 25:4165.
- Porschen R et al. Phase III study of capecitabine plus oxaliplatin compared with fluorouracil and leucovorin plus oxaliplatin in metastatic colorectal cancer: a final report of the AIO Colorectal Study Group. *J Clin Oncol* 2007; 25:4217.
15. Van Cutsem, E et al. Oral capecitabine compared with intravenous fluorouracil plus leucovorin in patients with metastatic colorectal cancer: Results of a large phase III study. *J Clin Oncol* 2001; 19:4097.
16. Hochster HS et al. Phase II study of uracil-tegafur with leucovorin in elderly (> 75 years old) patients with colorectal cancer: ECOG 1299. *J Clin Oncol* 2007; 25:5397.
17. Fuchs CS et al. Phase III comparison of two irinotecan dosing regimens in second-line therapy of metastatic colorectal cancer. *J Clin Oncol* 2003; 21:807.
18. Phase II, randomized trial comparing bevacizumab plus fluorouracil (FU)/leucovorin (LV) with FU/LV alone in patients with metastatic colorectal cancer. *J Clin Oncol* 2003; 21:60
- Saltz LB et al. Bevacizumab (Bev) in combination with XELOX or FOLFOX4: efficacy results from XELOX-1/No 16966, a randomized phase III trial in the first-line treatment of metastatic colorectal cancer (mCRC). 2007 Gastrointestinal Cancers Symposium. Abstract 238.
- Giantonio, BJ et al. Bevacizumab in combination with oxaliplatin, fluorouracil, and leucovorin (FOLFOX4) for previously treated metastatic colorectal cancer: Results from the Eastern Cooperative Oncology Group Study E3200. *J Clin Oncol* 2007; 25:1539
- Hurwitz, H et al. Bevacizumab plus irinotecan, fluorouracil, and leucovorin for metastatic colorectal cancer. *N Engl J Med* 2004; 350:2335.
19. Bokemeyer C et al. KRAS status and efficacy of first-line treatment of patients with metastatic colorectal cancer (mCRC) with FOLFOX with or without cetuximab: the OPUS experience. 2008 ASCO annual meeting. Abstract 4000.
- Van Cutsem E et al. KRAS status and efficacy in the first-line treatment of patients with metastatic colorectal cancer (mCRC) treated with or without cetuximab: the CRYSTAL experience. 2008 ASCO annual meeting. Abstract 2.
- Jonker DJ et al. Cetuximab for the treatment of colorectal cancer. *N Engl J Med* 2007; 357-2040.
- Sobrero AF et al. EPIC: phase III trial of cetuximab plus irinotecan after fluoropyrimidine and oxaliplatin failure in patients with metastatic colorectal cancer. *J Clin Oncol* 2008; 26:2311.
20. Ane L Appelt, John Pløen, Henrik Harling, Frank S Jensen, Lars H Jensen, Jens C R Jørgensen, Jan Lindebjerg, Søren R Rafaelsen, Anders Jakobsen (2015) High-dose chemoradiotherapy and watchful waiting for distal rectal cancer: a prospective observational study. *Lancet Oncol* 16, 919–927
21. FOLFOXIRI plus bevacizumab versus FOLFIRI plus bevacizumab as first-line treatment of patients with metastatic colorectal cancer: updated overall survival and molecular subgroup analyses of the open-label, phase 3 TRIBE study Chiara Cremolini et al *Vol 16*. October 2015; 1308
22. 衛生福利部中央健康保險署-藥品給付規定:第9節 抗癌瘤藥物 Antineoplastics drugs(民國 105 年 4 月 1 日)第 17 頁。
- 取自: http://www.nhi.gov.tw/webdata/webdata.aspx?menu=21&menu_id=713&webdata_id=2919



直腸癌第四期完治率定義:

- 1.Stage IIA，MMR(+) \rightarrow UFUR 服用滿 6 個月就算完治率
2. Stage IIA，MMR(+) \rightarrow 自費打化療滿 6 個月就算完治率
- 3.Stagr III、IV，但年紀大、擔心化療副作用，經團討論後可改用口服化療藥，服用滿 6 個月就算完治療
- 4.Stage IV，未治療轉安寧就算完治率
- 5.Stage IV，標靶+化療打完三個月就算完治率
- 6.Stage IV，標靶+化療未滿三個月轉安寧就算完治率
7. Stage IV，只接受腸造口術就算完治率
8. Stage IV，只接受 Palliative Radrotherapy 療程結束就算完治率